

# NPIC6C595-Q100

Power logic 8-bit shift register; open-drain outputs

Rev. 2 — 9 June 2020

Product data sheet

## 1. General description

---

The NPIC6C595-Q100 is an 8-bit serial-in/serial or parallel-out shift register with a storage register and open-drain outputs. Both the shift and storage register have separate clocks. The device features a serial input (DS) and a serial output (Q7S) to enable cascading and an asynchronous reset input (MR). A LOW on MR resets both the shift register and storage register. Data is shifted on the LOW-to-HIGH transitions of the SHCP input. The data in the shift register is transferred to the storage register on a LOW-to-HIGH transition of the STCP input and to the Q7S output on a LOW-to-HIGH transition of the SHCP input. If both clocks are connected together, the shift register is always one clock pulse ahead of the storage register. Data in the storage register drives the gate of the output extended-drain NMOS transistor whenever the output enable input ( $\overline{OE}$ ) is LOW. A HIGH on  $\overline{OE}$  causes the outputs to assume a high-impedance OFF-state. Operation of the  $\overline{OE}$  input does not affect the state of the registers. The open-drain outputs are 33 V/100 mA continuous current extended-drain NMOS transistors designed for use in systems that require moderate load power such as LEDs.

Integrated voltage clamps in the outputs provide protection against inductive transients making the device suitable for power driver applications such as relay, solenoids and other low-current or medium-voltage loads.

This product has been qualified to the Automotive Electronics Council (AEC) standard Q100 (Grade 1) and is suitable for use in automotive applications.

## 2. Features and benefits

---

- Automotive product qualification in accordance with AEC-Q100 (Grade 1)
  - Specified from -40 °C to +125 °C
- Low  $R_{DSon}$
- Eight Power EDNMOS transistor outputs of 100 mA continuous current
- 250 mA current limit capability
- Output clamping voltage 33 V
- 30 mJ avalanche energy capability
- All registers cleared with single input
- Low power consumption
- ESD protection:
  - HBM AEC-Q100-002 revision D exceeds 2500 V
  - CDM AEC-Q100-011 revision B exceeds 1000 V
- DHVQFN package with Side-Wettable Flanks enabling Automatic Optical Inspection (AOI) of solder joints

## 3. Applications

---

- LED sign
- Graphic status panel
- Fault status indicator

### 4. Ordering information

Table 1. Ordering information

Type number	Package			Version
	Temperature range	Name	Description	
NPIC6C595D-Q100	-40 °C to +125 °C	SO16	plastic small outline package; 16 leads; body width 3.9 mm	SOT109-1
NPIC6C595PW-Q100	-40 °C to +125 °C	TSSOP16	plastic thin shrink small outline package; 16 leads; body width 4.4 mm	SOT403-1
NPIC6C595BQ-Q100	-40 °C to +125 °C	DHVQFN16	plastic dual in-line compatible thermal enhanced very thin quad flat package; no leads; 16 terminals; body 2.5 × 3.5 × 0.85 mm	SOT763-1

### 5. Functional diagram

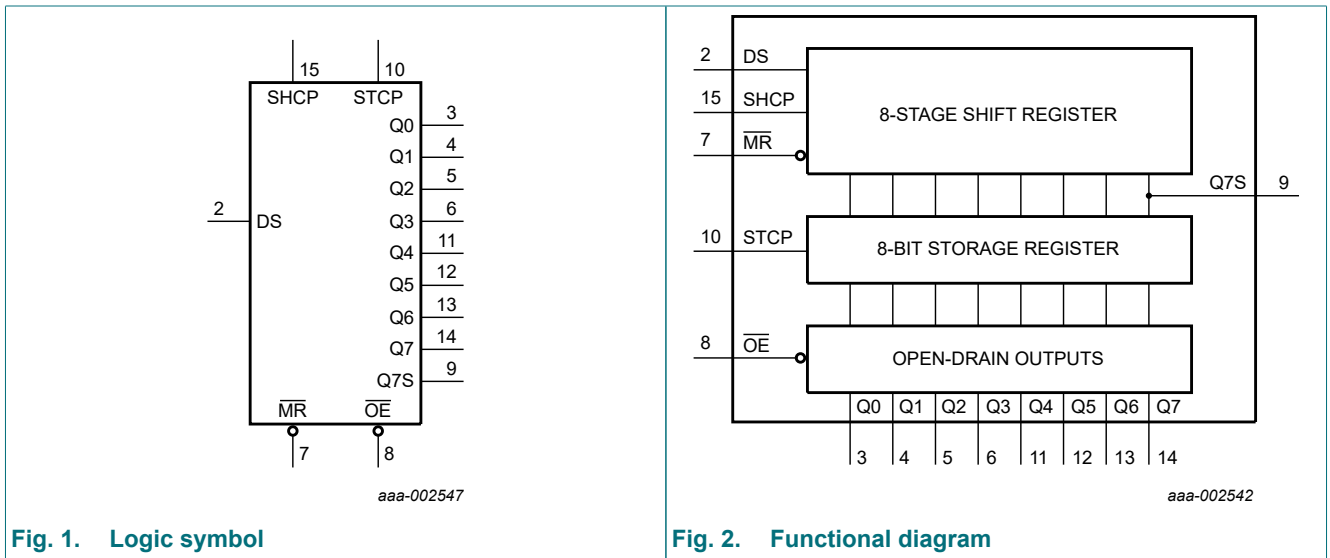

Fig. 1. Logic symbol

Fig. 2. Functional diagram

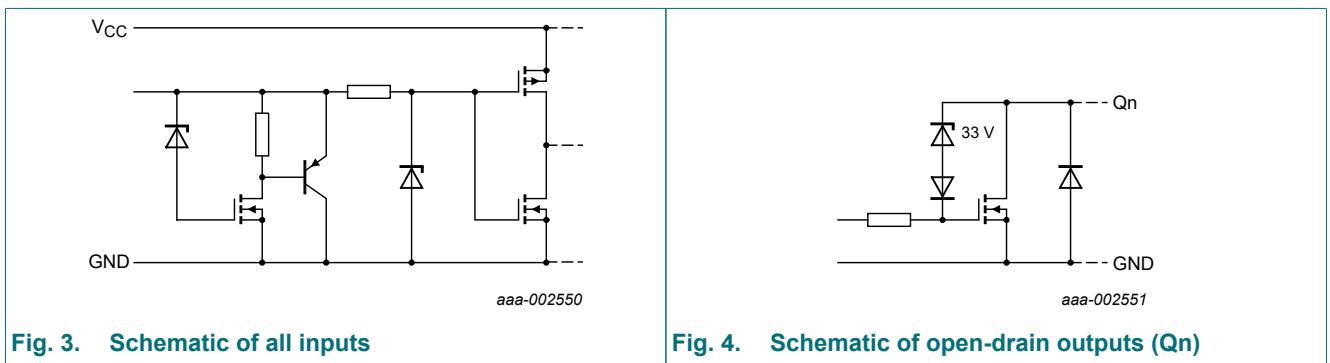

Fig. 3. Schematic of all inputs

Fig. 4. Schematic of open-drain outputs (Qn)

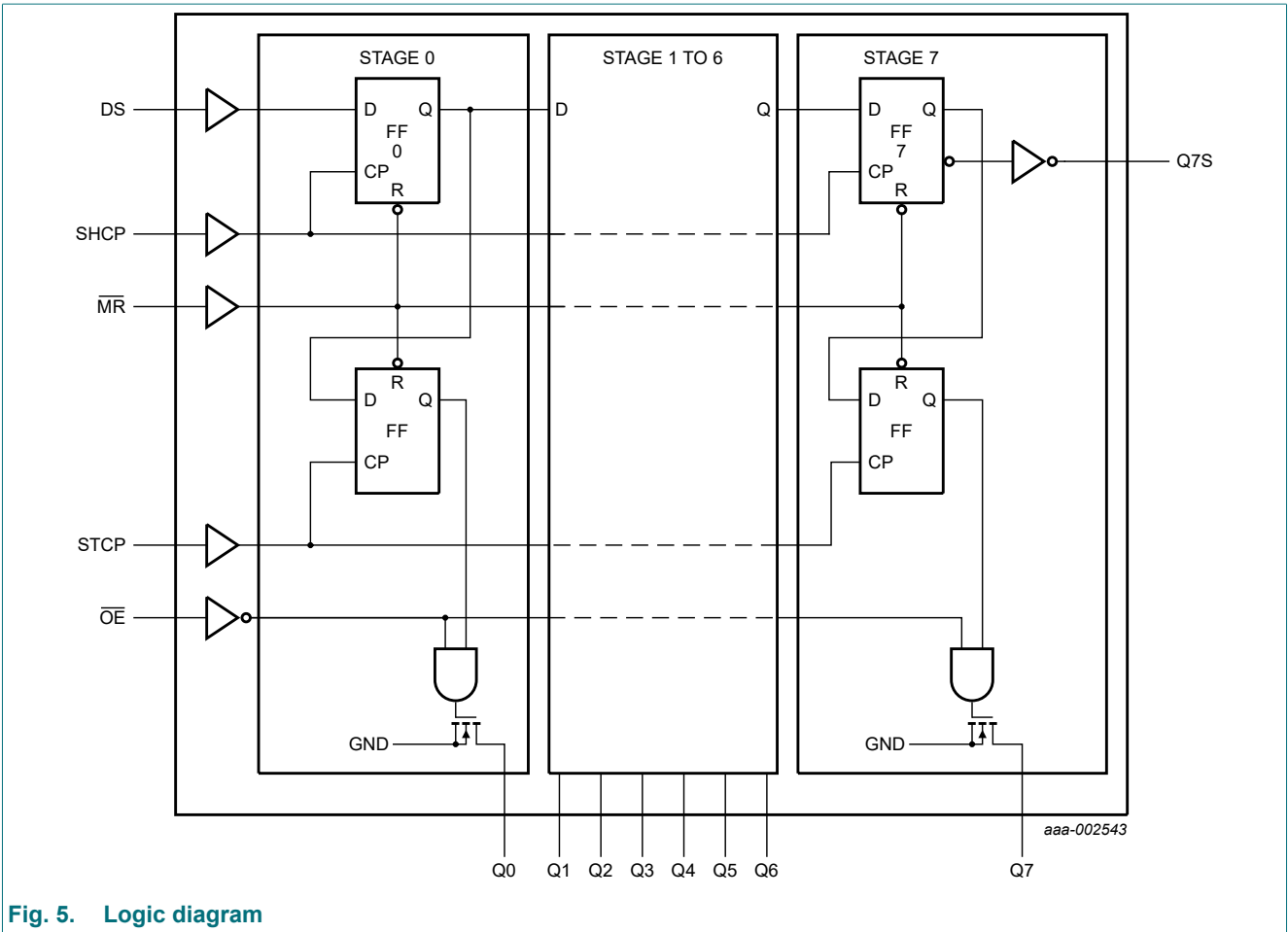

Fig. 5. Logic diagram

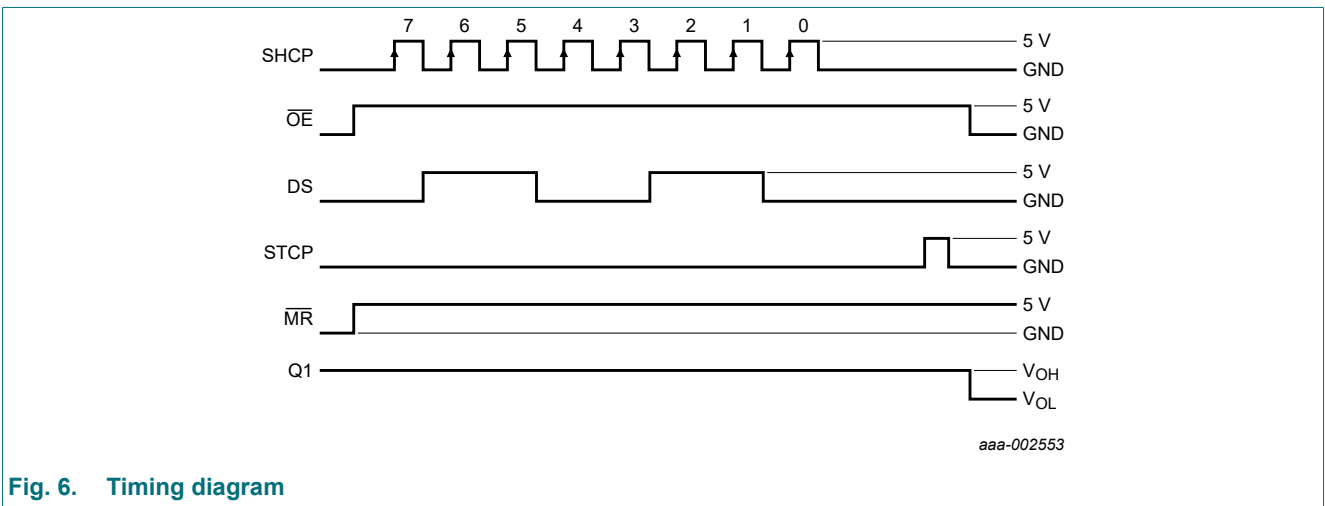
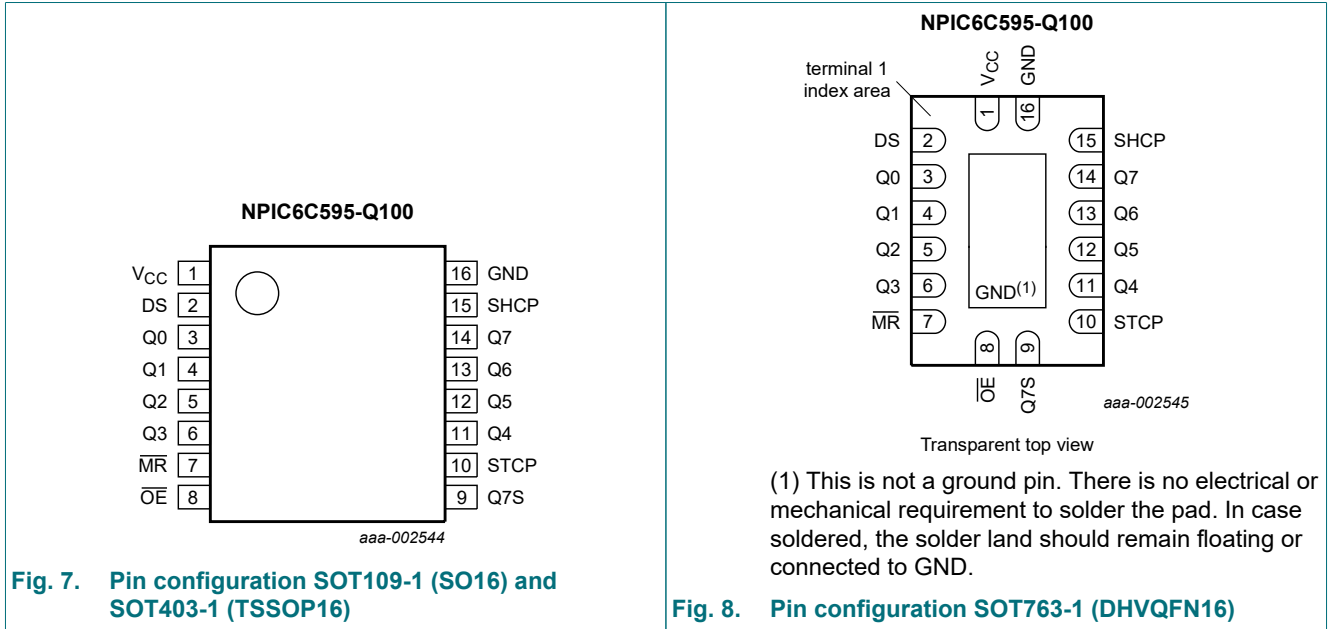

Fig. 6. Timing diagram

## 6. Pinning information

### 6.1. Pinning



### 6.2. Pin description

Table 2. Pin description

Symbol	Pin	Description
V <sub>CC</sub>	1	supply voltage
DS	2	serial data input
Q0, Q1, Q2, Q3, Q4, Q5, Q6, Q7	3, 4, 5, 6, 11, 12, 13, 14	parallel data output (open-drain)
MR	7	master reset (active LOW)
OE	8	output enable input (active LOW)
Q7S	9	serial data output
STCP	10	storage register clock input
SHCP	15	shift register clock input
GND	16	ground (0 V)

## 7. Limiting values

**Table 3. Limiting values**

In accordance with the Absolute Maximum Rating System (IEC 60134). Voltages are referenced to GND (ground = 0 V).

Symbol	Parameter	Conditions	Min	Max	Unit
$V_{CC}$	supply voltage		-0.5	+7.0	V
$V_I$	input voltage		-0.3	+7.0	V
$V_{DS}$	drain-source voltage	power EDNMOS drain-source voltage [1]	-	+33	V
$I_{d(SD)}$	source-drain diode current	continuous	-	250	mA
		pulsed [2]	-	500	mA
$I_D$	drain current	$T_{amb} = 25\text{ °C}$			
		continuous; each output; all outputs on	-	100	mA
		pulsed; each output; all outputs on [2]	-	250	mA
$I_{DM}$	peak drain current	single output; $T_{amb} = 25\text{ °C}$ [2]	-	250	mA
$E_{AS}$	non-repetitive avalanche energy	single pulse; see Fig. 9 [3]	-	30	mJ
$I_{AL}$	avalanche current	see Fig. 9 [3]	-	200	mA
$T_{stg}$	storage temperature		-65	+150	°C
$P_{tot}$	total power dissipation	$T_{amb} = 25\text{ °C}$ [4]			
		SO16	-	800	mW
		TSSOP16	-	725	mW
		DHVQFN16	-	1825	mW
		$T_{amb} = 125\text{ °C}$ [4]			
		SO16	-	160	mW
		TSSOP16	-	145	mW
		DHVQFN16	-	365	mW

[1] Each power EDNMOS source is internally connected to GND.

[2] Pulse duration  $\leq 100\ \mu\text{s}$  and duty cycle  $\leq 2\%$ .

[3]  $V_{DS} = 15\text{ V}$ ; starting junction temperature ( $T_j$ ) =  $25\text{ °C}$ ;  $L = 1.5\text{ H}$ ; avalanche current ( $I_{AL}$ ) =  $200\text{ mA}$ .

[4] For SOT109-1 (SO16) package:  $P_{tot}$  derates linearly with  $12.4\text{ mW/K}$  above  $110\text{ °C}$ .

For SOT403-1 (TSSOP16) package:  $P_{tot}$  derates linearly with  $8.5\text{ mW/K}$  above  $91\text{ °C}$ .

For SOT763-1 (DHVQFN16) package:  $P_{tot}$  derates linearly with  $11.2\text{ mW/K}$  above  $106\text{ °C}$ .

7.1. Test circuit and waveform

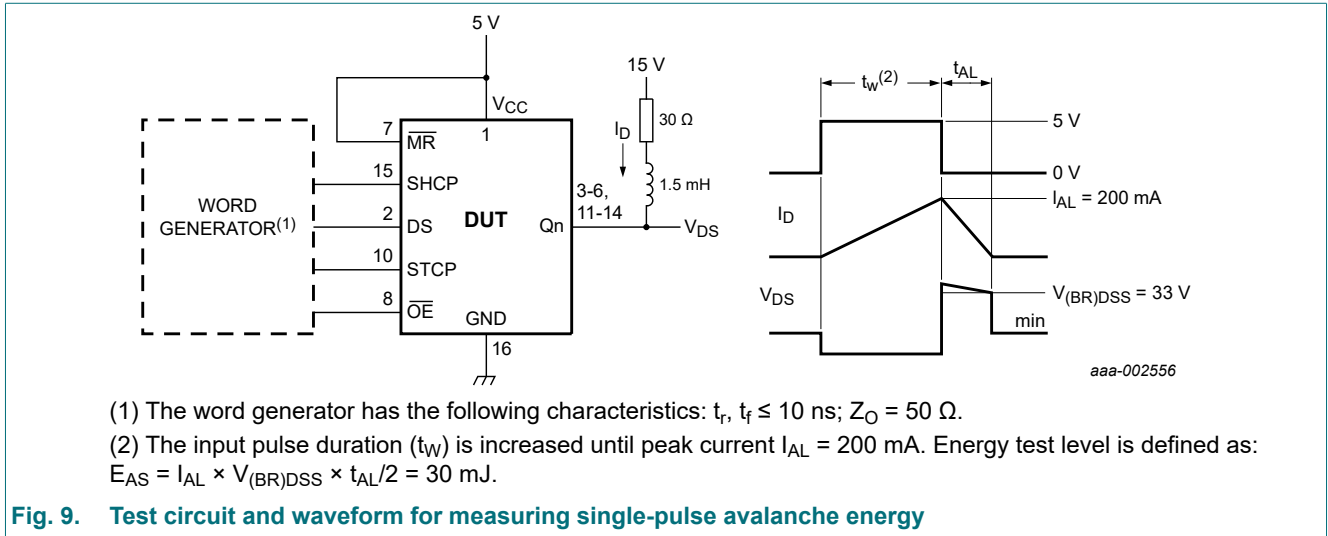

8. Recommended operating conditions

Table 4. Recommended operating conditions

Symbol	Parameter	Conditions	Min	Typ	Max	Unit
$V_{CC}$	supply voltage		4.5	-	5.5	V
$V_I$	input voltage		0	-	5.5	V
$I_D$	drain current	pulsed drain output current; $V_{CC} = 5 \text{ V}$ ; [1] [2] $T_{amb} = 25 \text{ }^\circ\text{C}$ ; all outputs on	-	-	250	mA
$T_{amb}$	ambient temperature		-40	-	+125	$^\circ\text{C}$

[1] Pulse duration  $\leq 100 \mu\text{s}$  and duty cycle  $\leq 2 \%$ .  
 [2] This technique should limit  $T_j - T_{amb}$  to  $10 \text{ }^\circ\text{C}$  maximum.

## 9. Static characteristics

**Table 5. Static characteristics**

At recommended operating conditions. Voltages are referenced to GND (ground = 0 V).

Symbol	Parameter	Conditions	V <sub>CC</sub> = 5.0 V; T <sub>amb</sub> = 25 °C			Unit
			Min	Typ	Max	
V <sub>IH</sub>	HIGH-level input voltage	V <sub>CC</sub> = 4.5 V to 5.5 V	0.85V <sub>CC</sub>	-	-	V
V <sub>IL</sub>	LOW-level input voltage	V <sub>CC</sub> = 4.5 V to 5.5 V	-	-	0.15V <sub>CC</sub>	V
V <sub>OH</sub>	HIGH-level output voltage	serial data output Q7S; V <sub>I</sub> = V <sub>IH</sub> or V <sub>IL</sub>				
		I <sub>O</sub> = -20 μA; V <sub>CC</sub> = 4.5 V	4.4	4.49	-	V
		I <sub>O</sub> = -4 mA; V <sub>CC</sub> = 4.5 V	4.0	4.2	-	V
V <sub>OL</sub>	LOW-level output voltage	serial data output Q7S; V <sub>I</sub> = V <sub>IH</sub> or V <sub>IL</sub>				
		I <sub>O</sub> = 20 μA; V <sub>CC</sub> = 4.5 V	-	0.005	0.1	V
		I <sub>O</sub> = 4 mA; V <sub>CC</sub> = 4.5 V	-	0.3	0.5	V
I <sub>IH</sub>	HIGH-level input current	V <sub>CC</sub> = 5.5 V; V <sub>I</sub> = V <sub>CC</sub>	-	-	1	μA
I <sub>IL</sub>	LOW-level input current	V <sub>CC</sub> = 5.5 V; V <sub>I</sub> = 0 V	-	-	-1	μA
V <sub>(BR)DSS</sub>	drain-source breakdown voltage	I <sub>D</sub> = 1 mA	33	37	-	V
V <sub>SD</sub>	source-drain voltage	diode forward voltage; I <sub>F</sub> = 100 mA	-	0.85	1.2	V
I <sub>CC</sub>	supply current	logic supply current; V <sub>CC</sub> = 5.5 V; V <sub>I</sub> = V <sub>CC</sub> or GND				
		all outputs off	-	0.004	200	μA
		all outputs on	-	0.006	500	μA
		all outputs off; SHCP = 5 MHz; C <sub>L</sub> = 30 pF; see Fig. 14 and Fig. 16	-	0.75	5	mA
I <sub>O(nom)</sub>	nominal output current	V <sub>DS</sub> = 0.5 V; T <sub>amb</sub> = 85 °C; I <sub>out</sub> = I <sub>D</sub> [1] [2] [3]	-	140	-	mA
I <sub>DSX</sub>	drain cut-off current	V <sub>CC</sub> = 5.5 V; V <sub>DS</sub> = 30 V	-	0.002	0.2	μA
		V <sub>CC</sub> = 5.5 V; V <sub>DS</sub> = 30 V; T <sub>amb</sub> = 125 °C	-	0.15	0.3	μA
R <sub>DSon</sub>	drain-source on-state resistance	see Fig. 17 and Fig. 18 [1] [2]				
		V <sub>CC</sub> = 4.5 V; I <sub>D</sub> = 50 mA	-	3.0	9	Ω
		V <sub>CC</sub> = 4.5 V; I <sub>D</sub> = 50 mA; T <sub>amb</sub> = 125 °C		5.4	12	Ω
		V <sub>CC</sub> = 4.5 V; I <sub>D</sub> = 100 mA	-	3.1	10	Ω

[1] This technique should limit T<sub>j</sub> - T<sub>amb</sub> to 10 °C maximum.

[2] These parameters are measured with voltage-sensing contacts separate from the current-carrying contacts.

[3] Nominal output current is defined for a consistent comparison between devices from different sources. It is the current that produces a voltage drop of 0.5 V at T<sub>amb</sub> = 85 °C.

## 10. Dynamic characteristics

**Table 6. Dynamic characteristics**

Voltages are referenced to GND (ground = 0 V); For test circuit see Fig. 14.

Symbol	Parameter	Conditions	V <sub>CC</sub> = 5.0 V; T <sub>amb</sub> = 25 °C			Unit
			Min	Typ	Max	
t <sub>PLH</sub>	LOW to HIGH propagation delay	$\overline{OE}$ to Qn; I <sub>D</sub> = 75 mA; see Fig. 10 and Fig. 19	-	97	-	ns
t <sub>PHL</sub>	HIGH to LOW propagation delay	$\overline{OE}$ to Qn; I <sub>D</sub> = 75 mA; see Fig. 10 and Fig. 19	-	9	-	ns
t <sub>r</sub>	rise time	$\overline{OE}$ to Qn; I <sub>D</sub> = 75 mA; see Fig. 10 and Fig. 19	-	60	-	ns
t <sub>f</sub>	fall time	$\overline{OE}$ to Qn; I <sub>D</sub> = 75 mA; see Fig. 10 and Fig. 19	-	18	-	ns
t <sub>pd</sub>	propagation delay	SHCP to Q7S; I <sub>D</sub> = 75 mA; see Fig. 11 [1]	-	5	-	ns
f <sub>max</sub>	maximum frequency	SHCP; I <sub>D</sub> = 75 mA; see Fig. 11 [2]	-	-	10	MHz
t <sub>rr</sub>	reverse recovery time	I <sub>F</sub> = 100 mA; dI/dt = 10 A/μs; see Fig. 13 [3] [4]	-	120	-	ns
t <sub>a</sub>	reverse recovery current rise time	I <sub>F</sub> = 100 mA; dI/dt = 10 A/μs; see Fig. 13 [3] [4]	-	100	-	ns
t <sub>su</sub>	set-up time	DS to SHCP; see Fig. 12	20	-	-	ns
t <sub>h</sub>	hold time	DS to SHCP; see Fig. 12	20	-	-	ns
t <sub>W</sub>	pulse width		40	-	-	ns

[1] t<sub>pd</sub> is the same as t<sub>PLH</sub> and t<sub>PHL</sub>.

[2] This is the maximum serial clock frequency assuming cascaded operation where serial data is passed from one stage to a second stage. The clock period allows for SHCP → Q7S propagation delay and setup time plus some timing margin.

[3] This technique should limit T<sub>j</sub> - T<sub>amb</sub> to 10 °C maximum.

[4] These parameters are measured with voltage-sensing contacts separate from the current-carrying contacts.

10.1. Waveforms and test circuit

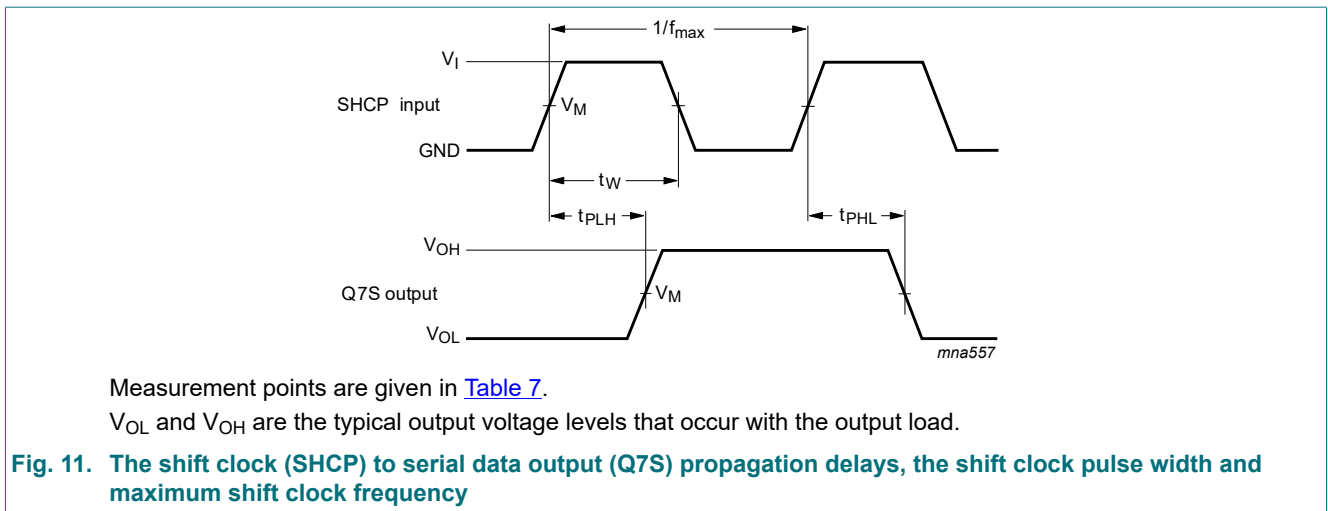
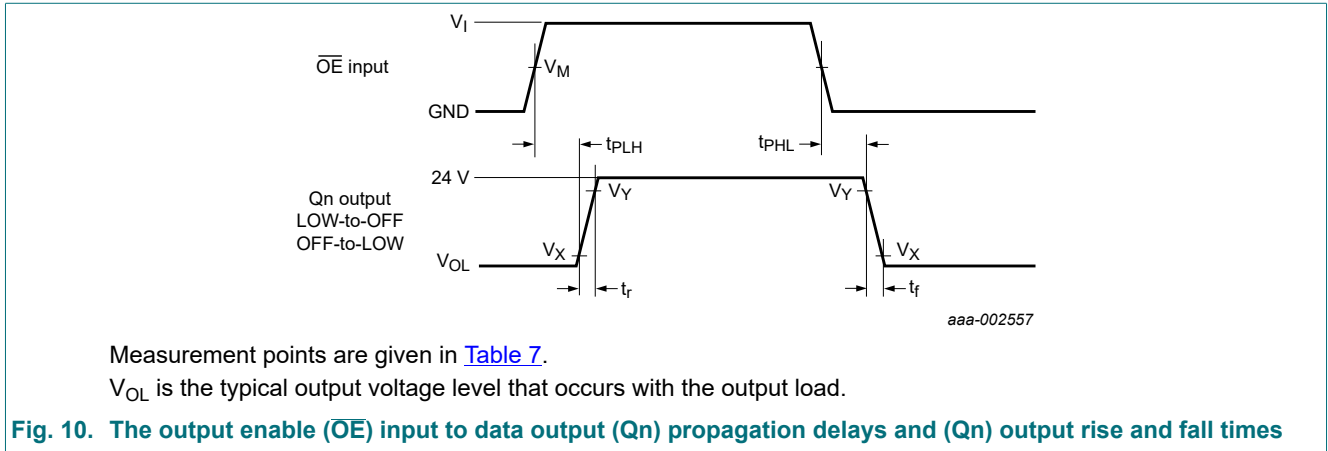
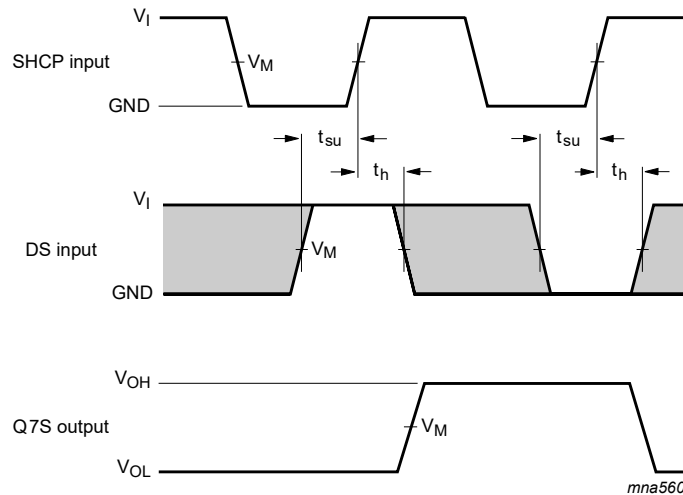

Table 7. Measurement points

Supply voltage	Input	Output		
$V_{CC}$	$V_M$	$V_M$	$V_X$	$V_Y$
5 V	$0.5V_{CC}$	$0.5V_{DS}$	$0.1V_{DS}$	$0.9V_{DS}$



Measurement points are given in [Table 8](#).

The shaded areas indicate when the input is permitted to change for predictable output performance.

$V_{OL}$  and  $V_{OH}$  are the typical output voltage levels that occur with the output load.

**Fig. 12. The data set-up and hold times for the serial data input (DS)**

**Table 8. Measurement points**

Supply voltage	Input	Output
$V_{CC}$	$V_M$	$V_M$
5 V	$0.5V_{CC}$	$0.5V_{CC}$

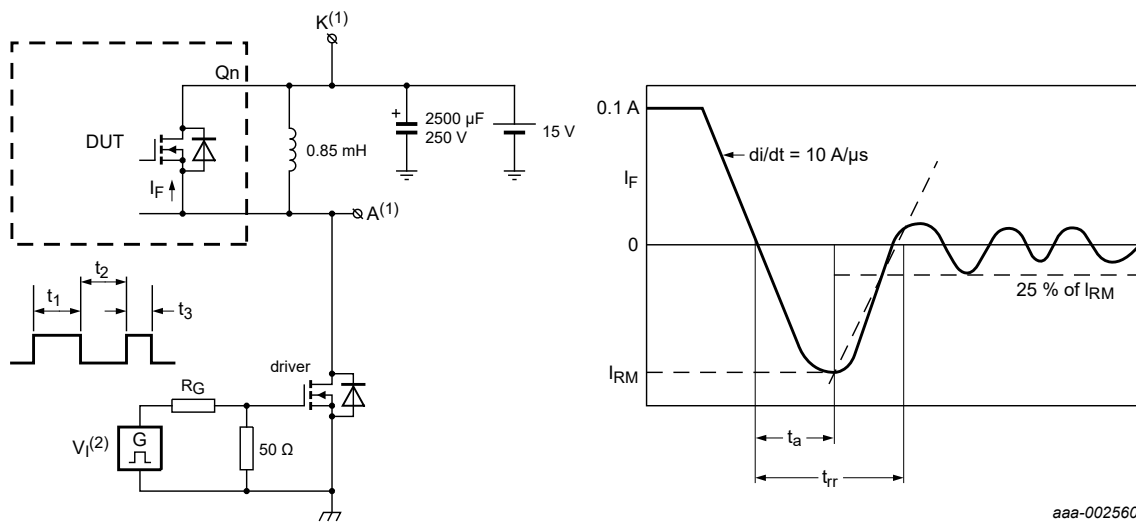

(1) The open-drain Qn terminal under test is connected to test point K. All other terminals are connected together and connected to test point A.

(2) The  $V_1$  amplitude and  $R_G$  are adjusted for  $di/dt = 10 \text{ A}/\mu\text{s}$ . A  $V_1$  double-pulse train is used to set  $I_F = 0.1 \text{ A}$ , where  $t_1 = 10 \mu\text{s}$ ,  $t_2 = 7 \mu\text{s}$  and  $t_3 = 3 \mu\text{s}$ .

**Fig. 13. Test circuit and waveform for measuring reverse recovery current**

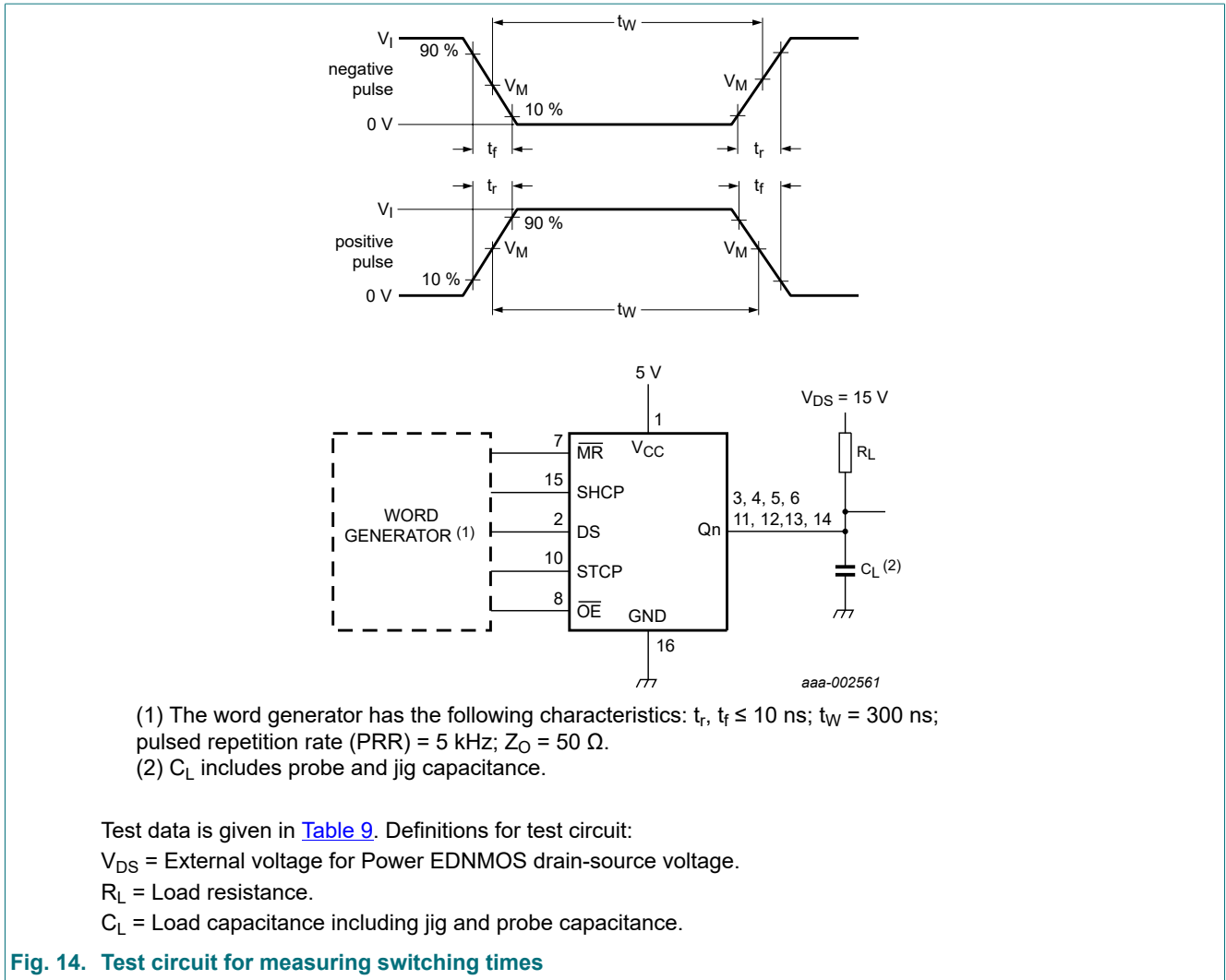
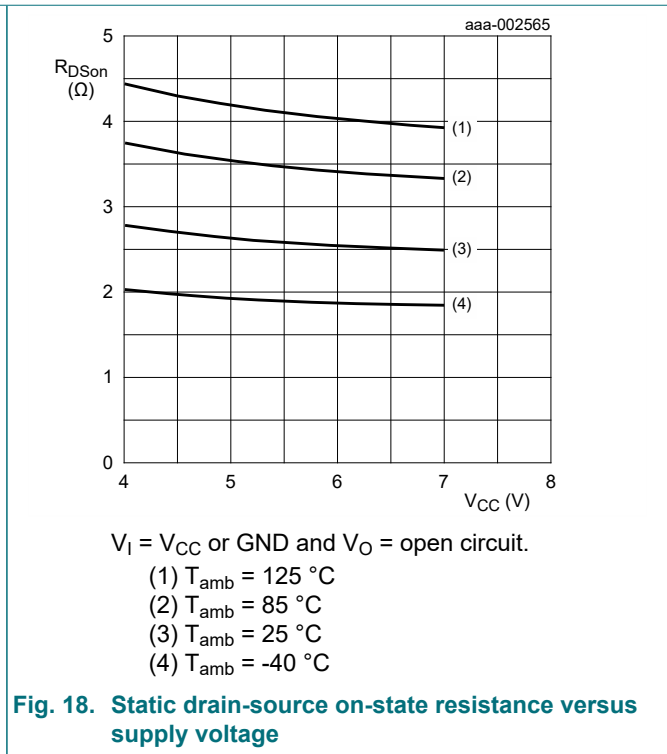
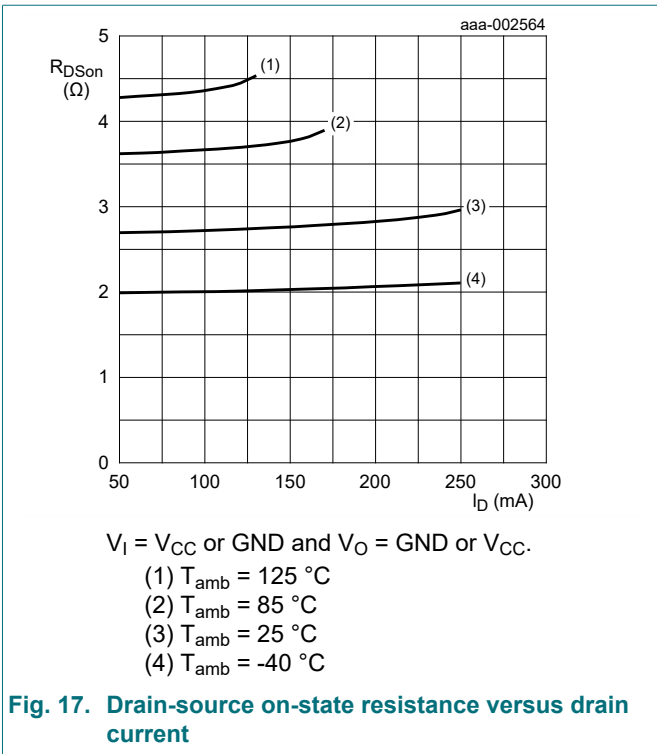
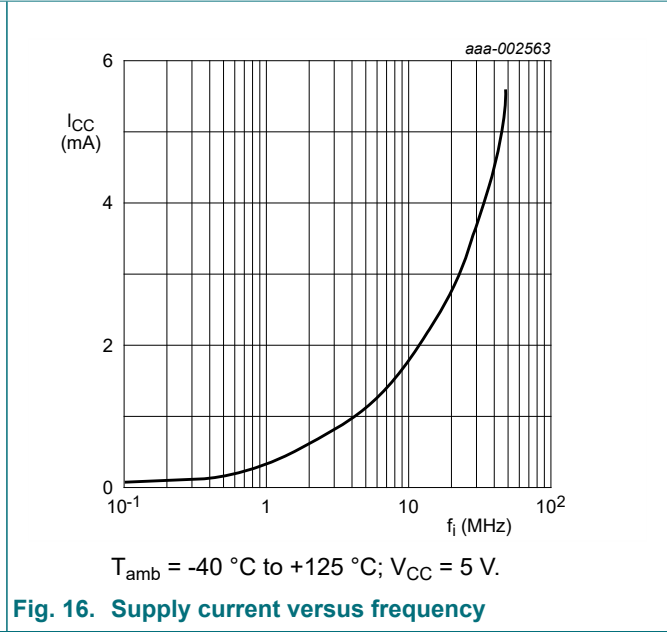
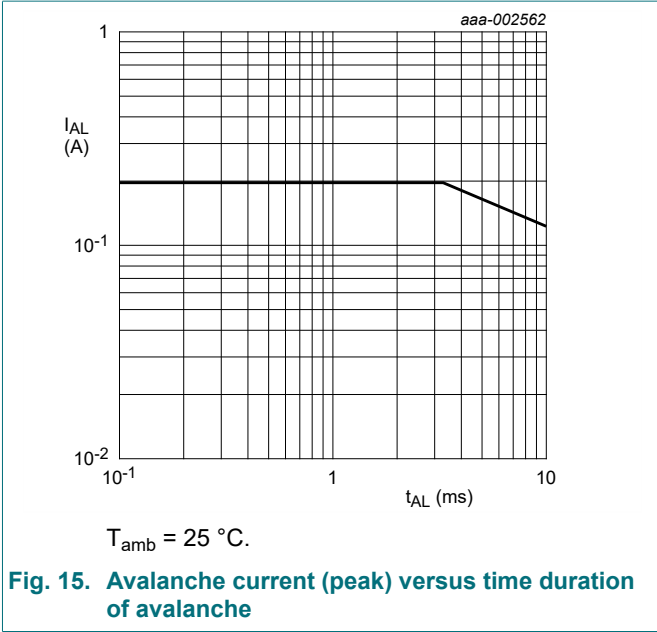
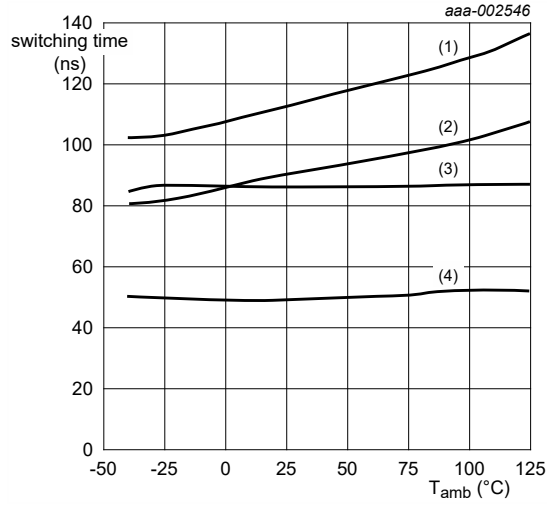

Table 9. Test data

Supply voltage	Input			Load	
	$V_I$	$t_r, t_f$	$V_M$	$C_L$	$R_L$
5 V	5 V	$\leq 10$ ns	50 %	30 pF	200 $\Omega$





I<sub>D</sub> = 75 mA, this technique should limit T<sub>j</sub> - T<sub>amb</sub> to 10 °C maximum.

- (1) t<sub>PLH</sub>.
- (2) t<sub>r</sub>.
- (3) t<sub>f</sub>.
- (4) t<sub>PHL</sub>.

Fig. 19. Switching time versus temperature

11. Package outline

SO16: plastic small outline package; 16 leads; body width 3.9 mm

SOT109-1

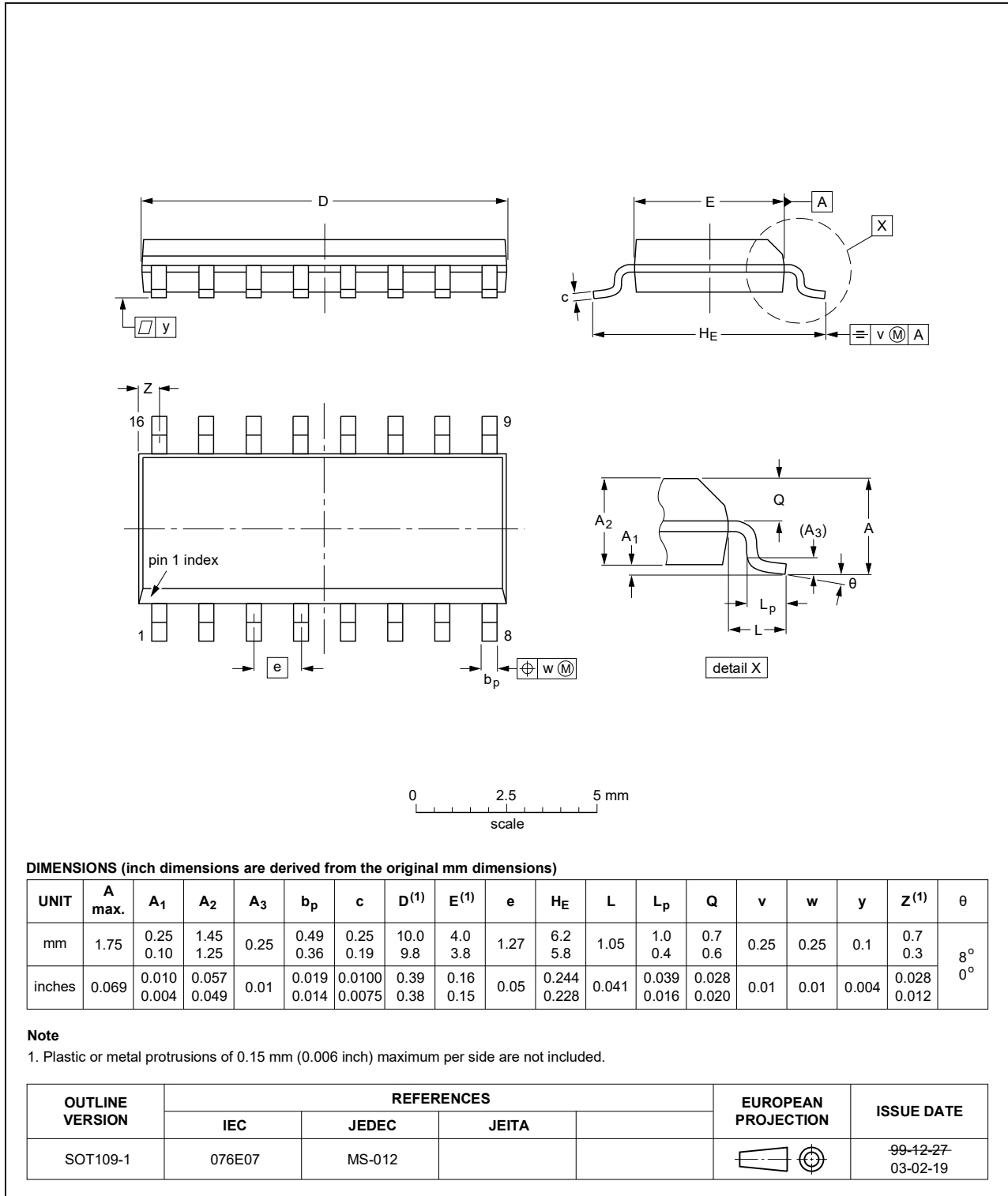

Fig. 20. Package outline SOT109-1 (SO16)

TSSOP16: plastic thin shrink small outline package; 16 leads; body width 4.4 mm

SOT403-1

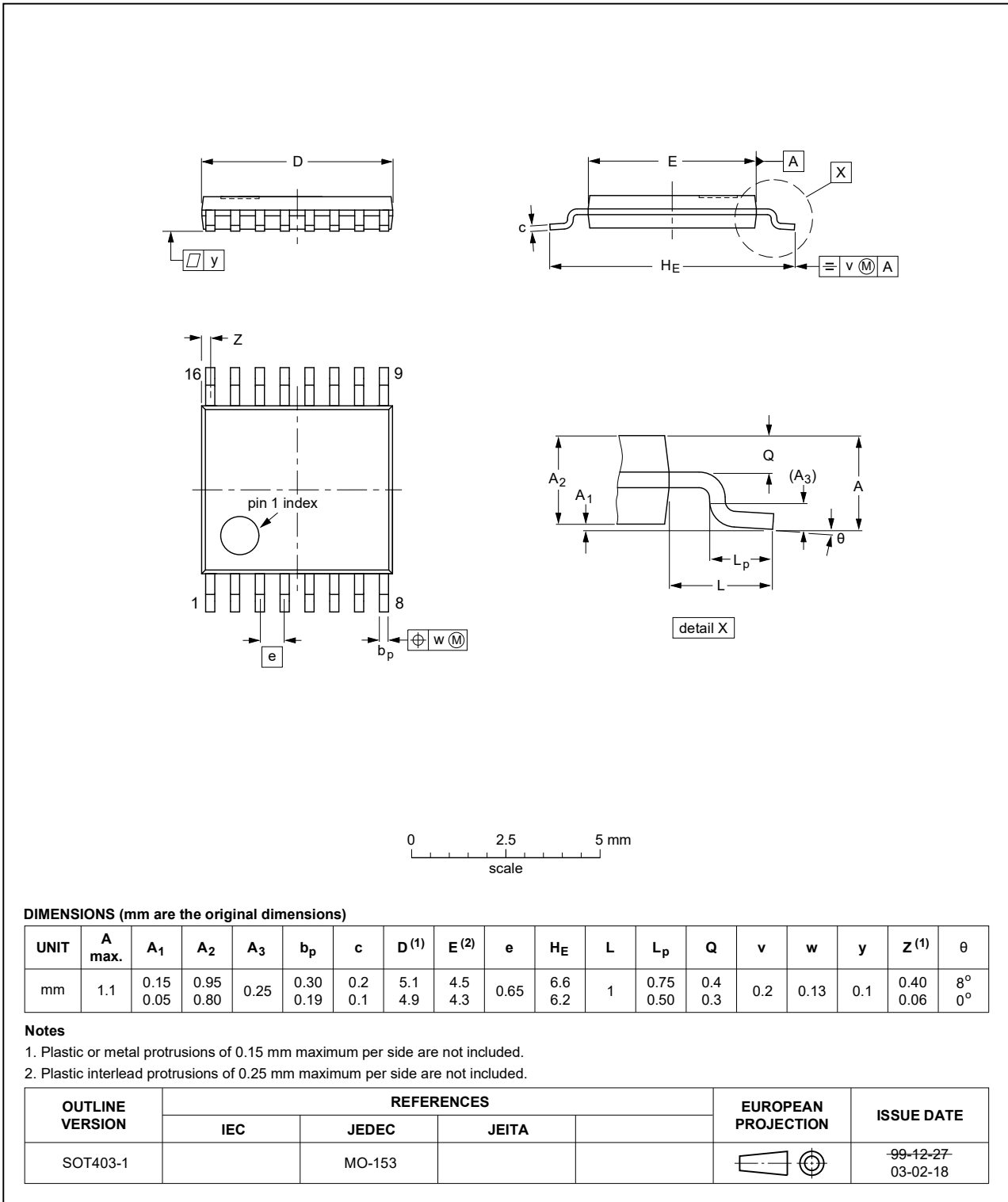

Fig. 21. Package outline SOT403-1 (TSSOP16)

DHVQFN16: plastic dual in-line compatible thermal enhanced very thin quad flat package; no leads; 16 terminals; body 2.5 x 3.5 x 0.85 mm

SOT763-1

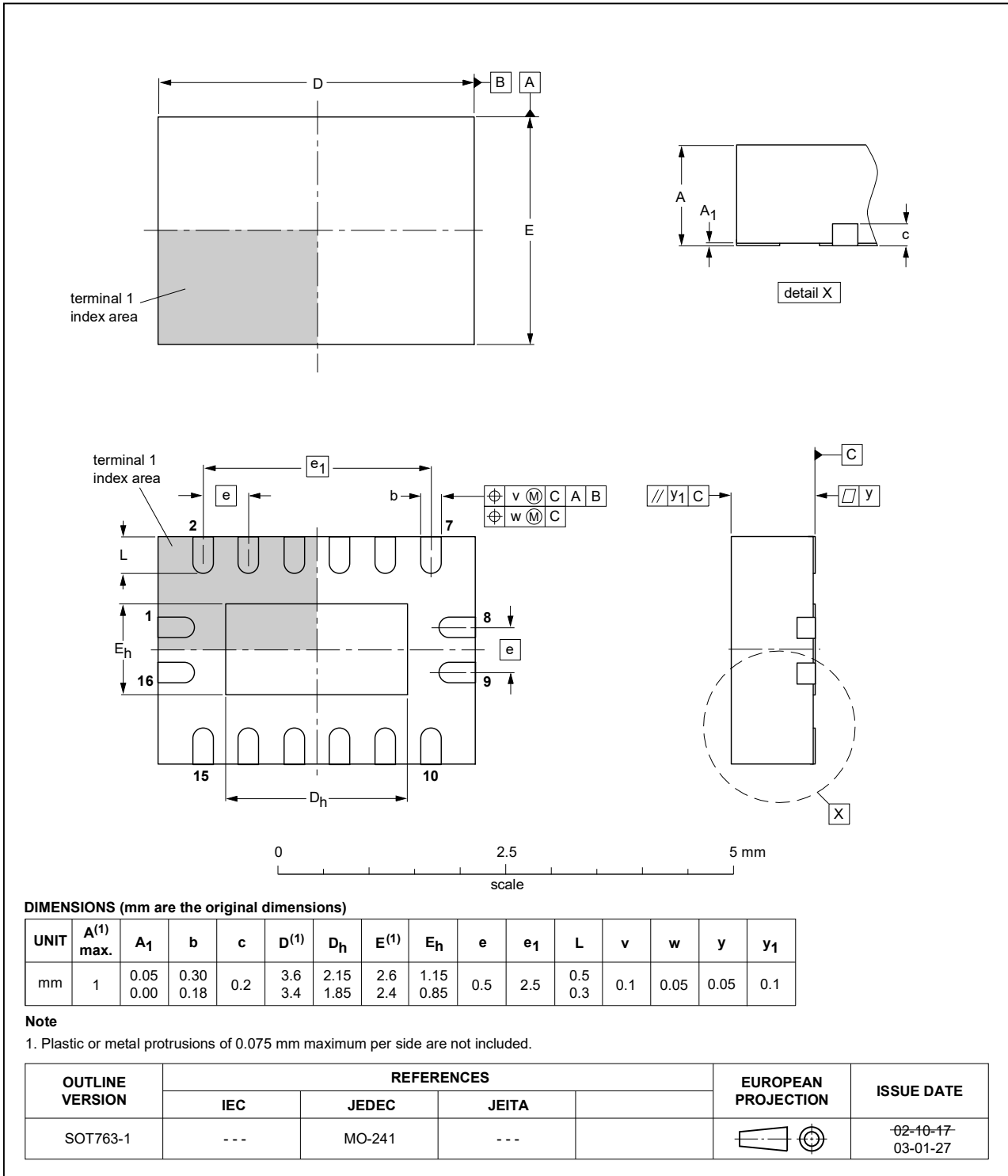

Fig. 22. Package outline SOT763-1 (DHVQFN16)

## 12. Abbreviations

Table 10. Abbreviations

Acronym	Description
CDM	Charged Device Model
DUT	Device Under Test
EDNMOS	Extended Drain Negative Metal Oxide Semiconductor
ESD	ElectroStatic Discharge
HBM	Human Body Model

## 13. Revision history

Table 11. Revision history

Document ID	Release date	Data sheet status	Change notice	Supersedes
NPIC6C595_Q100 v.2	20200609	Product data sheet	-	NPIC6C595_Q100 v.1
Modifications:	<ul style="list-style-type: none"> <li>The format of this data sheet has been redesigned to comply with the identity guidelines of Nexperia.</li> <li>Legal texts have been adapted to the new company name where appropriate.</li> <li><a href="#">Section 2</a> updated.</li> <li><a href="#">Fig. 5</a> updated; Latch changed to Flip Flop</li> <li><a href="#">Table 3</a>: Derating values for <math>P_{tot}</math> total power dissipation updated.</li> </ul>			
NPIC6C595_Q100 v.1	20120712	Product data sheet	-	-

## 14. Legal information

### Data sheet status

Document status [1][2]	Product status [3]	Definition
Objective [short] data sheet	Development	This document contains data from the objective specification for product development.
Preliminary [short] data sheet	Qualification	This document contains data from the preliminary specification.
Product [short] data sheet	Production	This document contains the product specification.

- [1] Please consult the most recently issued document before initiating or completing a design.
- [2] The term 'short data sheet' is explained in section "Definitions".
- [3] The product status of device(s) described in this document may have changed since this document was published and may differ in case of multiple devices. The latest product status information is available on the internet at <https://www.nexperia.com>.

### Definitions

**Draft** — The document is a draft version only. The content is still under internal review and subject to formal approval, which may result in modifications or additions. Nexperia does not give any representations or warranties as to the accuracy or completeness of information included herein and shall have no liability for the consequences of use of such information.

**Short data sheet** — A short data sheet is an extract from a full data sheet with the same product type number(s) and title. A short data sheet is intended for quick reference only and should not be relied upon to contain detailed and full information. For detailed and full information see the relevant full data sheet, which is available on request via the local Nexperia sales office. In case of any inconsistency or conflict with the short data sheet, the full data sheet shall prevail.

**Product specification** — The information and data provided in a Product data sheet shall define the specification of the product as agreed between Nexperia and its customer, unless Nexperia and customer have explicitly agreed otherwise in writing. In no event however, shall an agreement be valid in which the Nexperia product is deemed to offer functions and qualities beyond those described in the Product data sheet.

### Disclaimers

**Limited warranty and liability** — Information in this document is believed to be accurate and reliable. However, Nexperia does not give any representations or warranties, expressed or implied, as to the accuracy or completeness of such information and shall have no liability for the consequences of use of such information. Nexperia takes no responsibility for the content in this document if provided by an information source outside of Nexperia.

In no event shall Nexperia be liable for any indirect, incidental, punitive, special or consequential damages (including - without limitation - lost profits, lost savings, business interruption, costs related to the removal or replacement of any products or rework charges) whether or not such damages are based on tort (including negligence), warranty, breach of contract or any other legal theory.

Notwithstanding any damages that customer might incur for any reason whatsoever, Nexperia's aggregate and cumulative liability towards customer for the products described herein shall be limited in accordance with the Terms and conditions of commercial sale of Nexperia.

**Right to make changes** — Nexperia reserves the right to make changes to information published in this document, including without limitation specifications and product descriptions, at any time and without notice. This document supersedes and replaces all information supplied prior to the publication hereof.

**Suitability for use in automotive applications** — This Nexperia product has been qualified for use in automotive applications. Unless otherwise agreed in writing, the product is not designed, authorized or warranted to be suitable for use in life support, life-critical or safety-critical systems or

equipment, nor in applications where failure or malfunction of an Nexperia product can reasonably be expected to result in personal injury, death or severe property or environmental damage. Nexperia and its suppliers accept no liability for inclusion and/or use of Nexperia products in such equipment or applications and therefore such inclusion and/or use is at the customer's own risk.

**Quick reference data** — The Quick reference data is an extract of the product data given in the Limiting values and Characteristics sections of this document, and as such is not complete, exhaustive or legally binding.

**Applications** — Applications that are described herein for any of these products are for illustrative purposes only. Nexperia makes no representation or warranty that such applications will be suitable for the specified use without further testing or modification.

Customers are responsible for the design and operation of their applications and products using Nexperia products, and Nexperia accepts no liability for any assistance with applications or customer product design. It is customer's sole responsibility to determine whether the Nexperia product is suitable and fit for the customer's applications and products planned, as well as for the planned application and use of customer's third party customer(s). Customers should provide appropriate design and operating safeguards to minimize the risks associated with their applications and products.

Nexperia does not accept any liability related to any default, damage, costs or problem which is based on any weakness or default in the customer's applications or products, or the application or use by customer's third party customer(s). Customer is responsible for doing all necessary testing for the customer's applications and products using Nexperia products in order to avoid a default of the applications and the products or of the application or use by customer's third party customer(s). Nexperia does not accept any liability in this respect.

**Limiting values** — Stress above one or more limiting values (as defined in the Absolute Maximum Ratings System of IEC 60134) will cause permanent damage to the device. Limiting values are stress ratings only and (proper) operation of the device at these or any other conditions above those given in the Recommended operating conditions section (if present) or the Characteristics sections of this document is not warranted. Constant or repeated exposure to limiting values will permanently and irreversibly affect the quality and reliability of the device.

**Terms and conditions of commercial sale** — Nexperia products are sold subject to the general terms and conditions of commercial sale, as published at <http://www.nexperia.com/profile/terms>, unless otherwise agreed in a valid written individual agreement. In case an individual agreement is concluded only the terms and conditions of the respective agreement shall apply. Nexperia hereby expressly objects to applying the customer's general terms and conditions with regard to the purchase of Nexperia products by customer.

**No offer to sell or license** — Nothing in this document may be interpreted or construed as an offer to sell products that is open for acceptance or the grant, conveyance or implication of any license under any copyrights, patents or other industrial or intellectual property rights.

**Export control** — This document as well as the item(s) described herein may be subject to export control regulations. Export might require a prior authorization from competent authorities.

**Translations** — A non-English (translated) version of a document is for reference only. The English version shall prevail in case of any discrepancy between the translated and English versions.

### Trademarks

Notice: All referenced brands, product names, service names and trademarks are the property of their respective owners.

## Contents

---

<b>1. General description</b> .....	<b>1</b>
<b>2. Features and benefits</b> .....	<b>1</b>
<b>3. Applications</b> .....	<b>1</b>
<b>4. Ordering information</b> .....	<b>2</b>
<b>5. Functional diagram</b> .....	<b>2</b>
<b>6. Pinning information</b> .....	<b>4</b>
6.1. Pinning.....	4
6.2. Pin description.....	4
<b>7. Limiting values</b> .....	<b>5</b>
7.1. Test circuit and waveform.....	6
<b>8. Recommended operating conditions</b> .....	<b>6</b>
<b>9. Static characteristics</b> .....	<b>7</b>
<b>10. Dynamic characteristics</b> .....	<b>8</b>
10.1. Waveforms and test circuit.....	9
<b>11. Package outline</b> .....	<b>14</b>
<b>12. Abbreviations</b> .....	<b>17</b>
<b>13. Revision history</b> .....	<b>17</b>
<b>14. Legal information</b> .....	<b>18</b>

---

© Nexperia B.V. 2020. All rights reserved

For more information, please visit: <http://www.nexperia.com>

For sales office addresses, please send an email to: [salesaddresses@nexperia.com](mailto:salesaddresses@nexperia.com)

Date of release: 9 June 2020

---